

Series TLEX 8 - 11

THERMOSTATIC EXPANSION VALVES

FIXED ORIFICE, ADJUSTABLE SUPERHEAT SETTING, BALANCED PORT

PRODUCT DATA



Features

- Damped gas charge with MOP as standard
- Optional available with liquid charge
- Adjustable superheat setting
- Warm thermal head provides best reliability
- Solder connections
- External pressure equalisation
- Extreme durable due to stainless steel head and stainless steel diaphragm welded using protective gas
- Balanced port construction
- Fixed orifice
- Refrigerants: R22, R134a, R404A, R407C
Further refrigerants on request.

Specification

Nominal capacity range	64.1 to 95.8 kW R22
Evaporating temperature range	see table on page 2
Maximum pressure PS	see table on page 2
Maximum test pressure PF	see table on page 2 (simultaneous on all connections)
Max. ambient temperature	100 °C
Max. bulb temperature	gas charge: 140 °C liquid charge: 70 °C
Static superheat	approx. 3.5 K
Length of capillary tube	2 m
Bulb diameter	16 mm

Application

Thermostatic expansion valves series TLEX are used in plants with one or more refrigerant circuits, in particular for series installations such as air conditioning units, chiller units and heat pumps.

Materials

Body	brass
Thermal head	stainless steel
Connection tubes	copper

Thermal Charges and Temperature Ranges

1. Gas charge with pressure limiting MOP

Refrigerant	Evaporation temperature range	MOP	PS (bar(a))	PF (bar(a))
R22	+15 °C to -45 °C	MOP +15 °C	36	39.6
R134a	+15 °C to -40 °C	MOP +15 °C	34	37.4
R404A	+10 °C to -50 °C	MOP +10 °C	36	39.6
R407C	+15 °C to -30 °C	MOP +15 °C	36	39.6

Further refrigerants and MOP on request.

MOP valves protect the compressor by limiting the increase of suction pressure.

The MOP value should be chosen for the max. permissible suction pressure of the compressor or min. 5 K higher than the required evaporating temperature of the system.

With gas charged valves and MOP it is under all operating conditions necessary that the bulb is always colder than the capillary tube and the thermal head!

With the Honeywell TLEX series the thermal head is heated advantageously by the liquid refrigerant. The warm thermal head is on the safe side at any time.

2. Liquid charge

Refrigerants on request.

Capacities

Type	Orifice size	Nominal capacity (kW)*			
		R22	R134a	R404A	R407C
TLEX	8	64.1	43.3	45.1	61.8
	10	75.1	51.0	52.8	72.3
	11	95.8	65.0	67.4	92.3

* Capacities are based on $t_0 = +4$ °C, $t_c = +38$ °C and 1 K subcooled liquid refrigerant entering the valve.

For other operating conditions see capacity charts in Honeywell catalogue or consult the Honeywell software.

Dimensions and Weights

Type	Orifice size	Connections ODF			Weight (kg)
		Inlet (A)	Outlet (B)	Pressure equaliser (C)	
TLEX	8	22 mm	28 mm	6 mm	approx. 1.3
		22 mm	35 mm	6 mm	
	11	7/8"	1 1/8"	1/4"	
		7/8"	1 3/8"	1/4"	

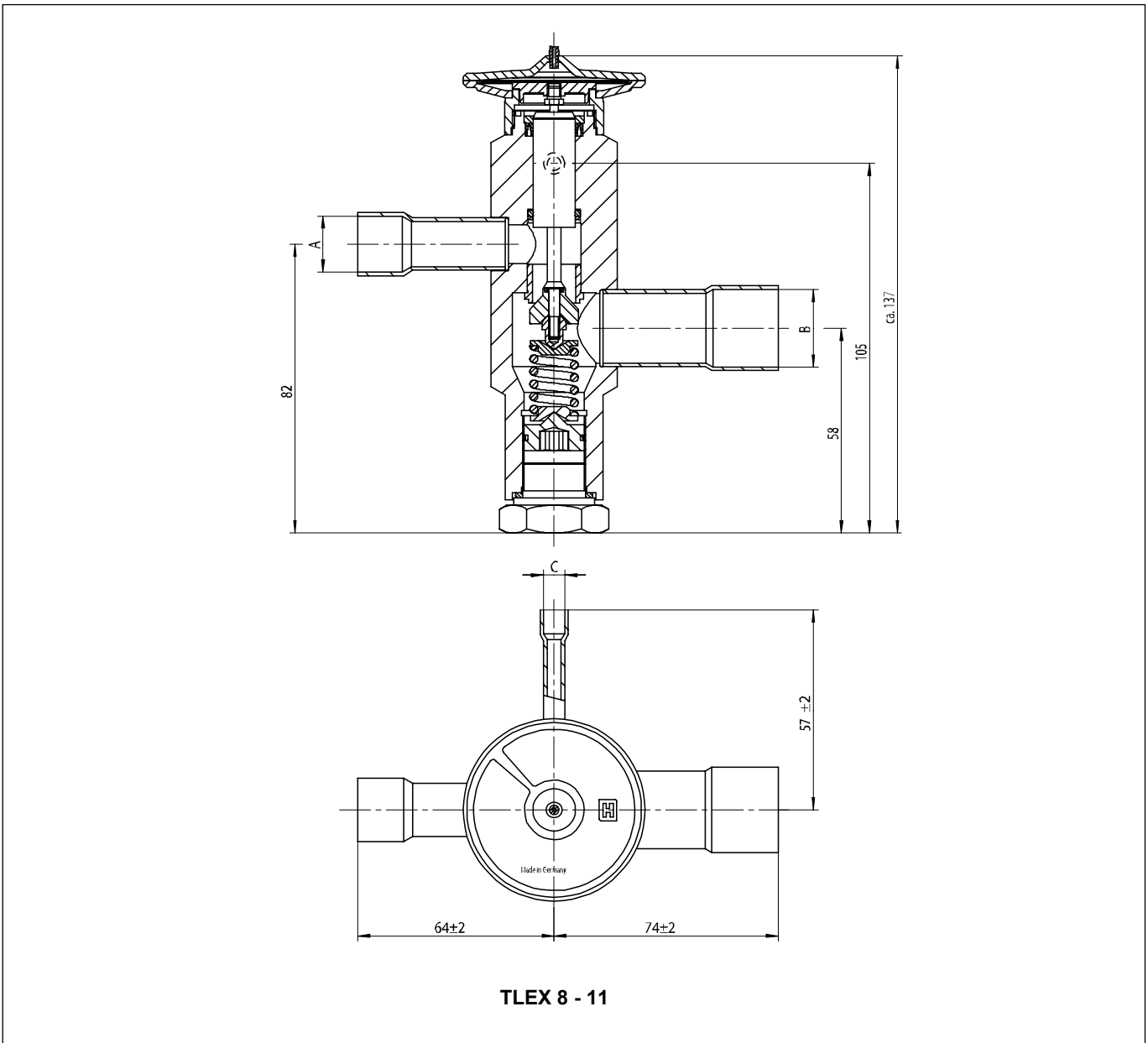

Type Code / Order Information

	TLEX	8	R134a	MOP +15 °C	22 mm x 28 mm
Series					
Orifice size					
Refrigerant					
MOP, evaporation temperature range					
Solder connection ODF (inlet x outlet)					

Installation

- The valves may be installed in any position.
- The external pressure equaliser line should be 6 mm or 1/4" in diameter and is to be connected downstream of the remote bulb. An overbowl is recommended in order to prevent the ingress of oil into the equaliser line.
- The bulb should preferably be positioned on the upper half of a horizontal suction line but never after a liquid trap. As a general rule, bulbs of expansion valves should be insulated to prevent them being affected by the ambient temperature.
- When soldering the valve, the valve body must not get warmer than 100 °C.
- Do not bend or squeeze the bulb when tightening the bulb clamp!
- Constructive modifications at the valve are not allowed.

Information for original equipment manufacturers:

The valve series TLEX can be customised to the requirements of your series device in an optimum way. Contact us!

Superheat Adjustment

In general the valves should be installed with the factory setting for the used refrigerant unaltered. This setting is calibrated for lowest superheating and optimum evaporator utilization. However, should it be necessary to adjust the superheat, turn the adjusting spindle as follows:

Turning clockwise	=	reduced refrigerant mass flow, increase of superheat
Turning counterclockwise	=	increased refrigerant mass flow, decrease of superheat

One turn of adjusting spindle alters superheat setting by approx. 0.3 bar. Increase of superheat setting results in a lower MOP value and vice versa.

Honeywell

Automation and Control Solutions

Honeywell GmbH
Hardhofweg
74821 Mosbach/Germany
Phone: +49 (0) 62 61 / 81-475
Fax: +49 (0) 62 61 / 81-461
E-Mail: cooling.mosbach@honeywell.com
www.honeywell-cooling.com

Manufactured for and on behalf of the
Environment and Combustion Controls
Division of Honeywell Technologies Sàrl,
1180 Rolle, Z. A. La Pièce 16, Switzerland
by its authorized representative Honeywell GmbH