

Series NMVL and NMX

LIQUID INJECTION VALVES

SUCTION PRESSURE CONTROLLED, INTERCHANGEABLE ORIFICE CARTRIDGES

PRODUCT DATA

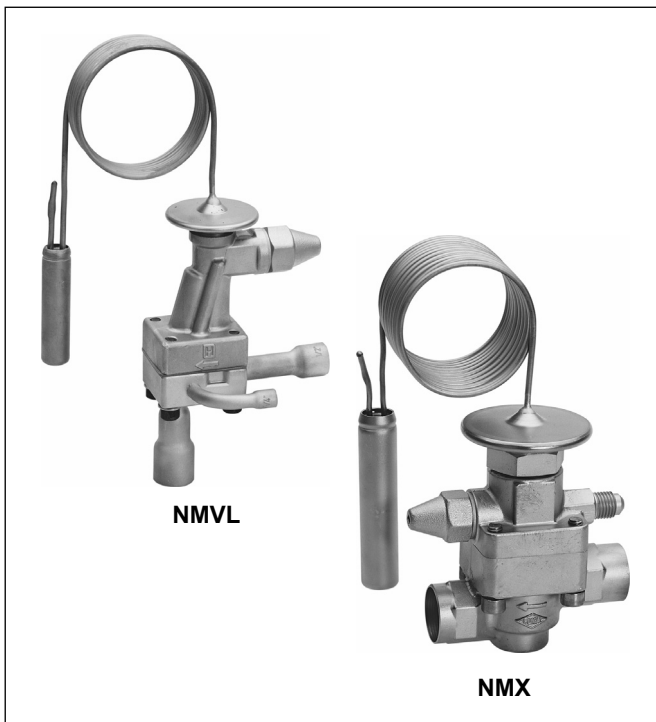

Features

- Suction gas controlled liquid injection valves
- Part programme containing:
 - Valve body head, orifice cartridge, connection base
- Honeywell NMVL:
 - Only one valve body head needed both for internal and external pressure equalisation
 - Connection for pressure coupler integrated in the solder base
 - solder base two-way or angle construction
- Honeywell NMX:
 - Balanced port
 - External pressure equalisation integrated in the valve body head
 - solder base two-way or angle construction
 - flare base two way construction
- Adjustable superheat setting
- Extreme durable due to stainless steel head and stainless steel diaphragm welded using protective gas
- Interchangeable orifice cartridges
- Liquid charge
- Refrigerants: R134a, R22, R404A, R407C, R507A
Further refrigerants on request.

Specification

Nominal capacity range	0.52 to 75.1 kW R22 (small orifice graduation for optimal control behaviour)
Temperature range	-50 °C to +65 °C
Maximum pressure PS	See table on page 2
Maximum test pressure PF	See table on page 2
Max. ambient temperature	70 °C
Max. bulb temperature	70 °C
Static superheat	See table on page 2
Length of capillary tube	NMVL: 1.5 m NMX: 3.0 m
Bulb diameter	NMVL: 12 mm NMX: 16 mm

Application

Honeywell thermostatic liquid injection valves series NMVL and NMX are used in refrigeration applications to reduce the temperature of the suction gas.

Depending on the superheat of the compressor suction gas, liquid refrigerant is injected into the suction line. The refrigerant is evaporating and thereby the suction gas is cooled down.

Suitable for plants in general refrigeration and for serial products such as air driers, dehumidifiers, chiller units or ice-making machines with hot gas bypass control valves, for temperature reduction in multiple stage units and for suction gas cooled compressors.

Materials

Body, base	brass
Thermal head	stainless steel
Connections	copper or brass

Thermal Charges and Static Superheat

Code for thermal charge	Superheat					PS (bar(a))	PF (bar(a))
	R134a	R22	R404A	R407C	R507A		
DA	-	15 K	21 K	12 K	21 K	34	37.4
TA	15 K	30 K	35 K	26 K	35 K	29	31.9
LB	30 K	45 K	-	40 K	-	29	31.9

Further refrigerants on request.

The superheat is based on $t_0 = +0\text{ °C}$.

Capacities

Type	Orifice size	Nominal capacity (kW)*				
		R134a	R22	R404A	R407C	R507A
NMVL	0.3	0.36	0.52	0.36	0.50	0.36
	0.5	0.69	0.99	0.68	0.95	0.69
	0.7	0.96	1.4	0.97	1.3	0.98
	1.0	1.4	2.0	1.4	1.9	1.4
	1.5	2.2	3.2	2.2	3.1	2.3
	2.0	2.9	4.0	2.8	3.9	2.9
	2.5	4.0	5.8	4.1	5.6	4.1
	3.0	6.6	9.3	6.5	8.9	6.6
	3.5	8.7	12.2	8.6	11.7	8.7
	4.5	11.8	17.0	12.0	16.4	12.1
NMX	4.75	15.9	22.4	15.8	21.6	15.9
	5	20.0	29.1	20.5	28.0	20.7
	6	27.6	42.4	29.8	40.8	30.1
	7	35.3	54.5	38.3	52.5	38.7
	8	43.3	64.1	45.1	61.8	45.6
	10	51.0	75.1	52.8	72.3	53.3

* Capacities are based on $t_0 = +4\text{ °C}$. $t_c = +38\text{ °C}$ and 1 K subcooled liquid refrigerant entering the valve.

For other operating conditions see capacity charts in Honeywell catalogue or consult the Honeywell software.

Dimensions and Weights

Type	Connections			Weight (kg)
	Inlet (A)	Outlet (B)	Pressure equalizer (C)	
NMVL	-	-	-	approx. 0.43
VD	-	-	-	approx. 0.02
VLS angle	6 mm ODF	10 mm ODF	-	approx. 0.16
	1/4" ODF	3/8" ODF	-	
	10 mm ODF	12 mm ODF	-	
	3/8" ODF	1/2" ODF	-	
	12 mm ODF	16 mm ODF	-	
	1/2" ODF	5/8" ODF	-	
VLSX angle	6 mm ODF	10 mm ODF	6 mm ODF	approx. 0.17
	1/4" ODF	3/8" ODF	1/4" ODF	
	10 mm ODF	12 mm ODF	6 mm ODF	
	3/8" ODF	1/2" ODF	1/4" ODF	
	12 mm ODF	16 mm ODF	6 mm ODF	
	1/2" ODF	5/8" ODF	1/4" ODF	
VLS two-way	10 mm ODF	12 mm ODF	-	approx. 0.16
	3/8" ODF	1/2" ODF	-	
	12 mm ODF	16 mm ODF	-	
	1/2" ODF	5/8" ODF	-	
VLSX two-way	10 mm ODF	12 mm ODF	6 mm ODF	approx. 0.17
	3/8" ODF	1/2" ODF	1/4" ODF	
	12 mm ODF	16 mm ODF	6 mm ODF	
	1/2" ODF	5/8" ODF	1/4" ODF	

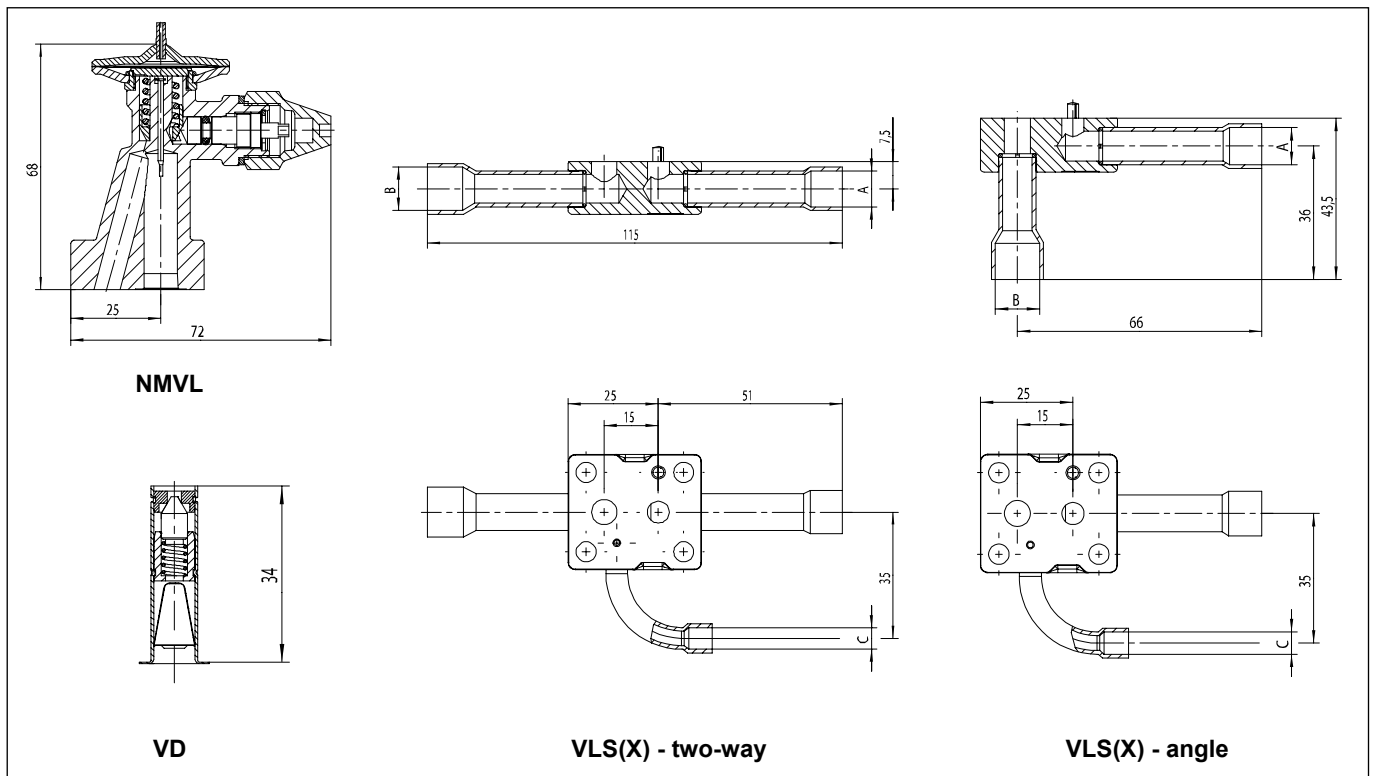

Type	Connections			Weight (kg)
	Inlet (A) + (B)	Outlet (C) + (D)	Pressure equalizer	
NMX	-	-	7/16" UNF	approx. 0.6
XD	-	-	-	approx. 0.14
XLS two-way	12 + 16 mm ODF	16 + 22 mm ODF	-	approx. 0.41
	1/2" + 5/8" ODF	5/8" + 7/8" ODF	-	
XLS angle	12 + 15 mm ODF	16 + 22 mm ODF	-	approx. 0.32
	1/2" + 5/8" ODF	5/8" + 7/8" ODF	-	
XBS two-way	7/8" UNF	7/8" UNF	-	approx. 0.49

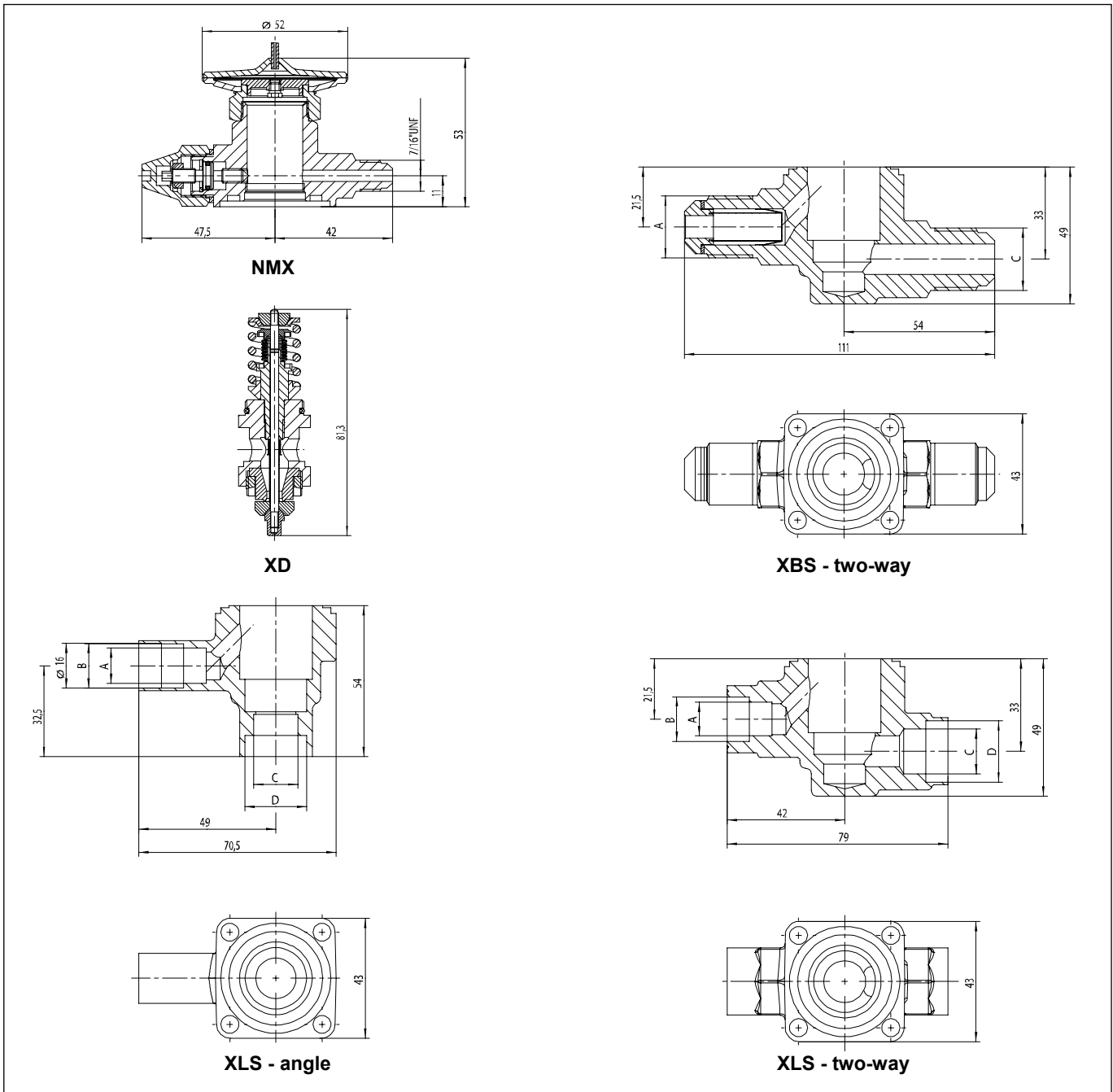

Type Code / Order Information (Part Programme)

1. Valve body head

	NMVL		DA
Series (NMVL, NMX)			
Code for thermal charge			

2. Orifice cartridge

	VD		0.5
Series (VD, XD)			
Orifice size			

3. Connection base

	VLS	X		10 mm ODF x 12 mm ODF		W
Series (VLS, XLS, XBS)						
Pressure equalizer VLS: X = external () = internal						
Connection size (Inlet x Outlet)						
D = two-way construction W = angle construction						

Installation

- The valves may be installed in any position.
- The external pressure equaliser line (VLSX and NMX) should be 6 mm or 1/4" in diameter. It is connected to the suction line downstream of the remote bulb. An overbowl is recommended in order to prevent the ingress of oil into the equaliser line.
- The bulb should preferably be positioned on the upper half of a horizontal suction line but never after a liquid trap. As a general rule, bulbs of liquid injection valves should be insulated to prevent them being affected by the ambient temperature.
- Do not bend or squeeze the bulb when tightening the bulb clamp.
- Never quench the solder base with water after soldering, this may cause cracks and distort the sealing surfaces.
- When tightening flare nuts of the flare connections grip at wrench flats on the valve body.
- The screws fixing the valve body head to the base must be tightened in diagonal sequence. Torque 12 Nm for NMVL and 20 Nm for NMX.
- Constructive modifications at the valve are not allowed.

Superheat Adjustment

In general the Honeywell liquid injection valves should be installed with the factory setting for the used refrigerant unaltered.

This superheat adjustment is calibrated for the above mentioned superheat and optimal control behaviour. However, should it be necessary to adjust the superheat, turn the adjusting spindle as follows:

Turning clockwise	=	reduced refrigerant mass flow, increase of superheat
Turning counterclockwise	=	increased refrigerant mass flow, decrease of superheat

One turn of the adjusting spindle alters superheat setting by approx. 0.55 bar for NMVL and 0.3 bar for NMX.

Application Sample

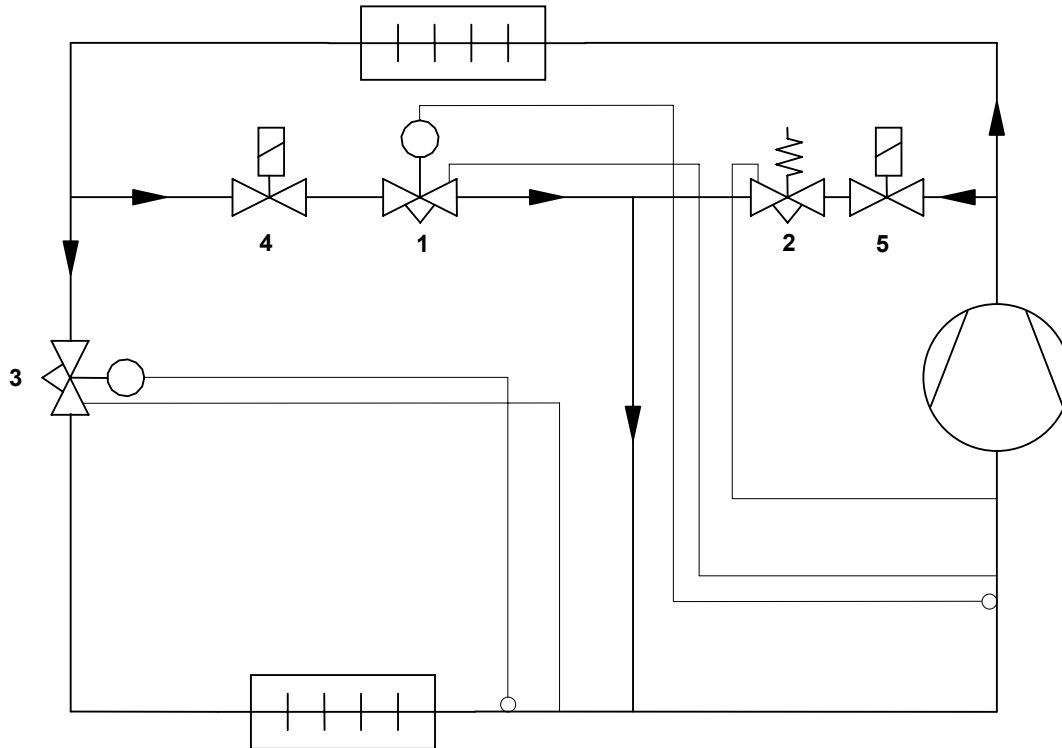

Power control with hot gas bypass valve and temperature reduction of suction gas with liquid injection valve

- 1** Liquid injection valve
- 2** Hot gas bypass valve
- 3** Thermostatic expansion valve
- 4** Liquid - solenoid valve
- 5** hot gas - solenoid valve

Honeywell

Automation and Control Solutions

Honeywell GmbH
 Hardhofweg
 74821 Mosbach/Germany
 Phone: +49 (0) 62 61 / 81-475
 Fax: +49 (0) 62 61 / 81-461
 E-Mail: cooling.mosbach@honeywell.com
www.honeywell-cooling.com

Manufactured for and on behalf of the
 Environment and Combustion Controls
 Division of Honeywell Technologies Sàrl,
 1180 Rolle, Z. A. La Pièce 16, Switzerland
 by its authorized representative Honeywell GmbH